



SIDE-POWER Thruster Systems

SE IP
- 80/185 T
- 120/215 T

Installation Manual



SLEIPNER MOTOR AS

P.O. Box 519
N-1612 Fredrikstad
Norway
www.side-power.com

Document id: 2685

Revision: 7

Date: 2019



Made in Norway

© Sleipner Motor AS 2019

Bow Installation Instructions

Bow Installation Considerations and Precautions	3
Thruster Measurements	4
Thruster Specifications	5
Technical Specifications	5
Positioning of the tunnel / thruster	6
Tunnel Length	7
Tunnel installation in sailboats	8
Water Deflection	9
Tunnel ends	10
Tunnel installation	11 - 12
Stern tunnel installation	13

Thruster Installation Instructions

Thruster Installation Considerations and Precautions	14
Gear Leg & Motor Bracket Installation	15
Propeller Installation	16
Motor Installation	17
Thruster Electrical Installation	18
Electrical Specifications	19
Control Panel Cable Installation	20
Visual Wiring Diagram	21
Technical Wiring Diagram	22
Control Panel Installation	23

Checklist for DC and IP Thrusters 24**Spare Parts 25****Warranty statement 25****DECLARATION OF CONFORMITY**

MC_0020



Sleipner Motor AS
P.O. Box 519, Arne Svendsensgt. 6-8
N-1612 Fredrikstad, Norway

Declare that this product with accompanying standard control systems complies with the essential health and safety requirements according to:

DIRECTIVE 2013/53/EU
DIRECTIVE 2014/30/EU
DIRECTIVE 2014/35/EU

It is the installers responsibility

When installing Side-Power equipment to follow the outlined regulations/ classification rules (electrical/ mechanical) according to international or special national regulations. Instructions in this guide cannot be guaranteed to comply with global electric/ mechanic regulations/ classification rules.

It is the installers responsibility

To follow all health and safety laws in accordance with their local outlined regulations/ classification rules.

Before installation, it is important that the installer reads this guide to ensure necessary acquaintance with this product.

The recommendations made in this manual are guidelines ONLY, and Sleipner Motor AS (Side-Power) strongly recommend that before installation, advice is obtained from a naval architect familiar with the particular vessel and regulations/ classifications.

This manual is intended to support educated/ experienced staff and is therefore not sufficient in all details for professional installation. *(NB: These instructions are only general instruction. If you are not skilled to do this work, please contact professional installers for assistance.)*

All electrical work must be done by a licensed professional.

IMPORTANT

Faulty installation of the tunnel, thruster or panel will render all warranty given by Sleipner Motor AS void.

MC_0038

EN

Bow Installation Considerations and Precautions

MC_0031

- The thruster must NOT be installed in compartments that require ignition proof electric equipment. If necessary, make a separate compartment. ***(NB: If installing an IP assembly, it has been tested to be fully ignition protected so that it can be installed in areas with possible explosive gases in accordance with ISO 8846)***
- The electromotor will generate some carbon dust so any storage compartments must be separated from the thruster to prevent nearby items from becoming dusty/ dirty. ***(NB: IP version motors do not generate dust)***
- Installing the electromotor in a small compartment must be ventilated to ensure cooling of the electromotor.
- If the height of the room you are installing the thruster is limited, it can be installed horizontally or at any angle in-between.
 - If the electromotor is positioned more than 30° off vertical, it must be supported separately.
 - Beware of keeping installation within advised measurements. No part of the propeller or gear house must be outside the tunnel.
- Do not install the thruster in a position where you need to cut a stiffener/ stringer/ support for the hull integrity without checking with the boat builder this can be done safely.
- The electromotor, its components, contacts/ plugs or other joints in the control cables must be mounted so they will remain dry at all times.
- We advise painting the gear house and propellers with antifouling. ***(NB: Do not paint the anodes, sealings or propeller shafts)***
- Do not finish the inside of the tunnel with a layer of gelcoat/ topcoat or similar. There is only room for a thin coat of primer and two layers of anti-fouling between the tunnel and the props.
- Don't install the electromotor at close range to easily flammable objects as it will reach over 100°C before the temperature switch is activated.
- Do not store items close to the thruster motor as it can reach 100°C. Any loose items near the thruster motor can cause problems with electrical wiring coming loose and short-circuiting.

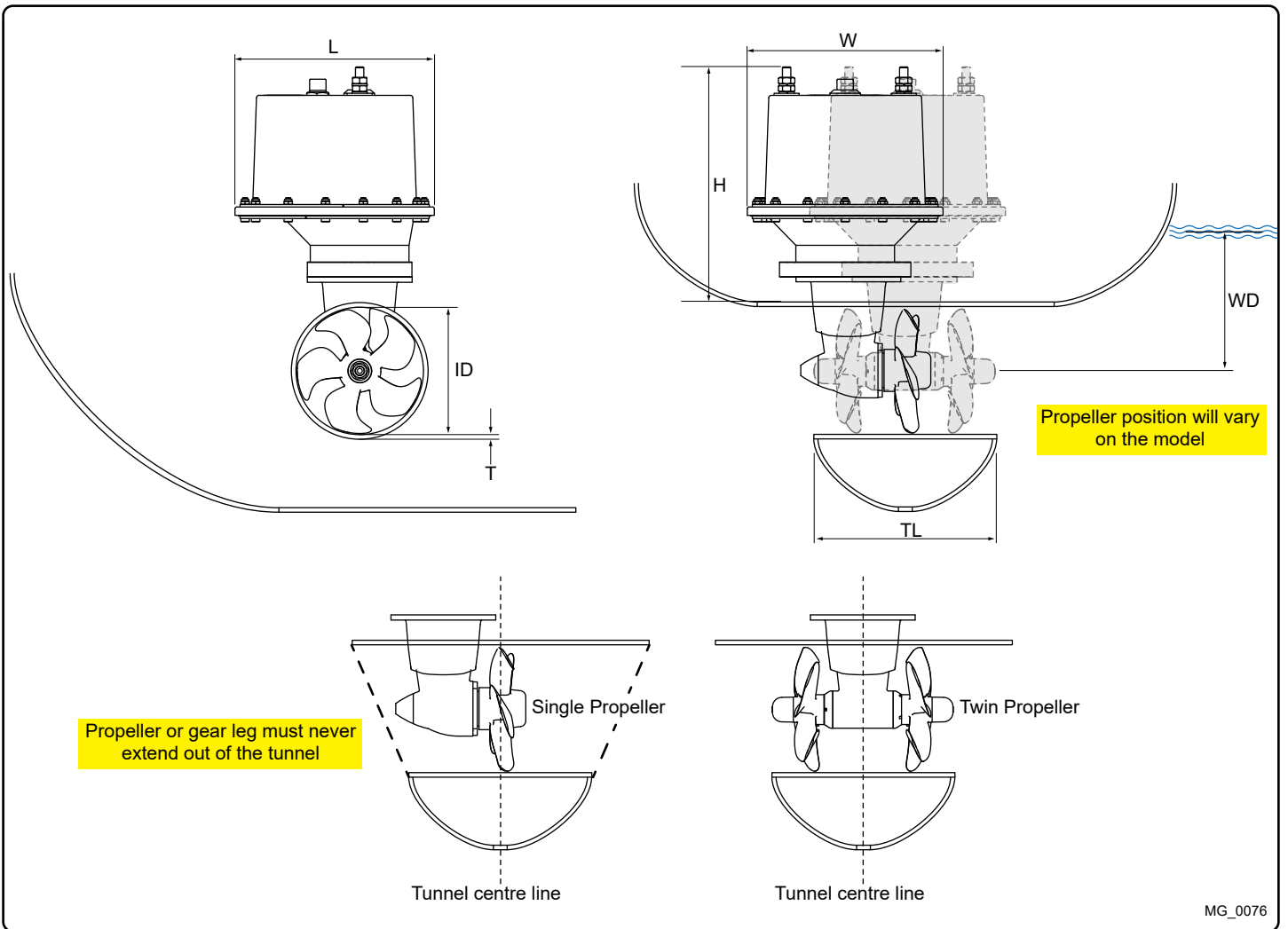

EN **Thruster Measurements** MC_0131

Measurement code	Measurement description	* IP 80 12v		* IP 80 24v		* IP 120 24v	
		mm	inch	mm	inch	mm	inch
ID	Internal tunnel diameter	185	7,28	185	7,28	215	8,46
H	Motor Height	406	15,98	406	15,98	501	19,72
W	Width	262	10,31	262	10,31	306	12,05
L	Length	327	12,87	327	12,87	381	15,00
WD	Water Depth	185	7,28	185	7,28	215	8,46
TL	Minimum tunnel length	179	7,05	179	7,05	233	9,17
TL (recommended)	Recommended tunnel length	216	8,50	216	8,50	276	10,87
T (min)	Minimum tunnel wall thickness	6	0,24	6	0,24	6	0,24
T (max)	Maximum tunnel wall thickness	8	0,31	8	0,31	8	0,31

*Valid for SE IP & SEP IP

description	* 80	* 100	* 120	* 130	* 150
Available DC System (v)	12v & 24v	12v & 24v	24v	12v & 24v	24v
Thrust 12v or 24v (kg * lbs)	96 kg * 212 lbs	116 kg * 256 lbs	139 kg * 306 lbs	160 kg * 352 lbs	182 kg * 400 lbs
Thrust 10.5v or 21v (kg * lbs)	80 kg * 176 lbs	100 kg * 220 lbs	120 kg * 264 lbs	130 kg * 284 lbs	150 kg * 330 lbs
Typical Boat Size (m * ft)	10m - 15m * 35ft - 48ft	12m - 17m * 35ft - 15ft	13m - 18m * 42ft - 60ft	13m - 19m * 42ft - 62ft	14m - 20m * 44ft - 64ft
Propulsion System	Twin	Twin	Twin	Twin	Twin
Power (kw * Hp)	4.4kw * 6hp	6.3kw * 8.4hp	6.4kw * 8.55hp	6.5kw * 8.7hp	8.8kw * 11.8hp
Weight (kg * lbs)	20kg * 44lbs	31kg * 68lbs	34kg * 74lbs	37kg * 77lbs	38kg * 79lbs
Minimum Battery Capacity (CCA) 12v * 24v * 48v	550 * 300	750 * 400	400	750 * 400	560

description	* 170
Available DC System (v)	24v
Thrust 12v or 24v (kg * lbs)	210 kg * 462 lbs
Thrust 10.5v or 21v (kg * lbs)	170 kg * 374 lbs
Typical Boat Size (m * ft)	15m - 22m * 50ft - 70ft
Propulsion System	Twin Counter Rotating
Power (kw * Hp)	8kw * 11.8hp
Weight (kg * lbs)	44kg * 97lbs
Minimum Battery Capacity (CCA) 12v * 24v * 48v	550

*Valid for SE / SE IP & SEP / SEP IP

- Motor:** Custom made reversible DC-motor.
- Gearhouse:** Seawater resistant bronze. Ballbearing at propeller shaft and a combination of ball bearing and slide bearing at driveshaft.
- Motor bracket:** Seawater resistant aluminium, galvanically insulated from the motor.
- Ignition Protection:** Conforms to ISO 8846
- Tunnel:** Cross spun with rowing G.R.P tunnel. (Steel & aluminium tunnels available at request.)
- Propeller:** 5-blade skewback "Q-prop" propeller, fibreglass reinforced composite.
- Batteries:** Minimum recommended battery capacity (cold crank capacity by DIN/SAE standard) *SEE 'ELECTRICAL SPECIFICATIONS*
- Max. use:** S2 = 3 min. or appr. 7-10% within a limited time frame.
- Safety:** Electronic time-lapse device protects against sudden change of drive direction. The electric thermal cut-off switch in electromotor protects against overheating (auto reset when electro motor cools down).
Flexible coupling between electro-motor and driveshaft protects electromotor and gear system if propeller jams.
If using the original Sidepower panel, the panel shuts off automatically 6 minutes after last use.
An integrated microprocessor monitors solenoids, reducing wear and risk of solenoid lock-in. Auto-stop of the thruster in case of accidental solenoid lock-in or if run signal is continuous for more than 3 minutes

Fig. 1

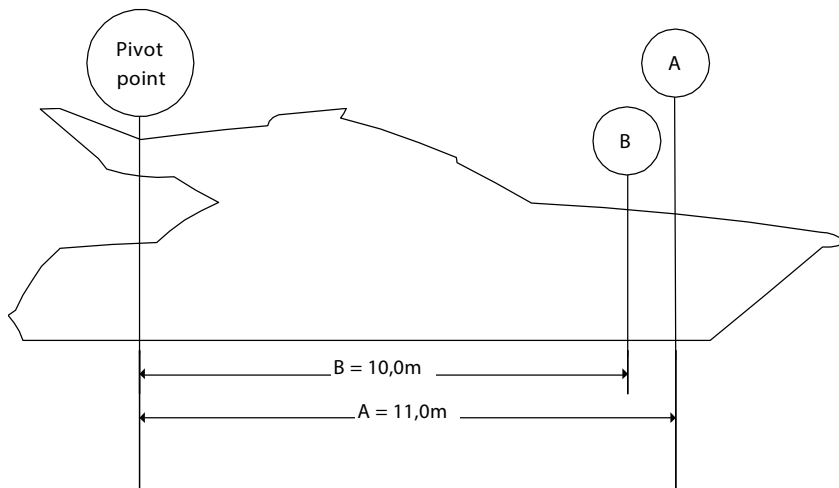
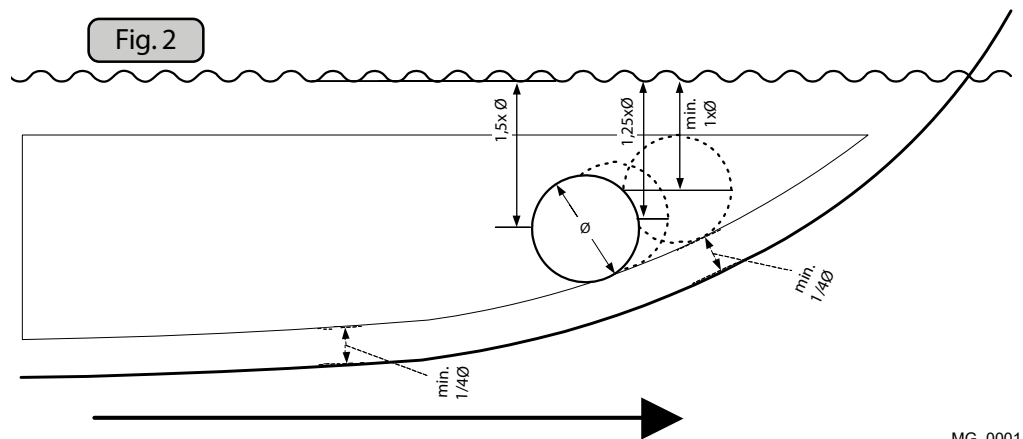

Fig. 2



MG_0001

EN

Positioning of the tunnel / thruster

MC_0003

Aim to install the thruster as far forward as possible (Fig. 1)

Due to the leverage effect around the boats' pivot point. The relative distance difference from the boat pivots' point to the thruster will determine the amount of real thrust for the boats, rotation.

Example :

A: 100kg thrust x 11m leverage = 1100kgm torque to rotate the boat

B: 100kg thrust x 10m leverage = 1000kgm torque to rotate the boat

In position A you will get 10% more thrust to turn the boat around.

Aim to install the thruster as deep as possible under the waterline (Fig. 2)

Two reasons:

1. So it does not suck air down from the surface which will reduce thrust performance and increase noise levels during operation.
2. To get as much water pressure as possible to receive maximum efficiency from the thruster.

The centre of the tunnel should be a minimum of 1 x the tunnel diameter below the waterline. However the installer must make evaluations based on thruster performance, boat type and operating conditions. For average performance the thruster it is at least 1.25 x tunnel diameter (✓) below the waterline. For best performance, the distance should be 1.5 x tunnel diameter (✓✓) below the waterline. **(NB: The position of the tunnel should not be a minimum of 1/4 of the diameter of the tunnel from the boat keel.)**

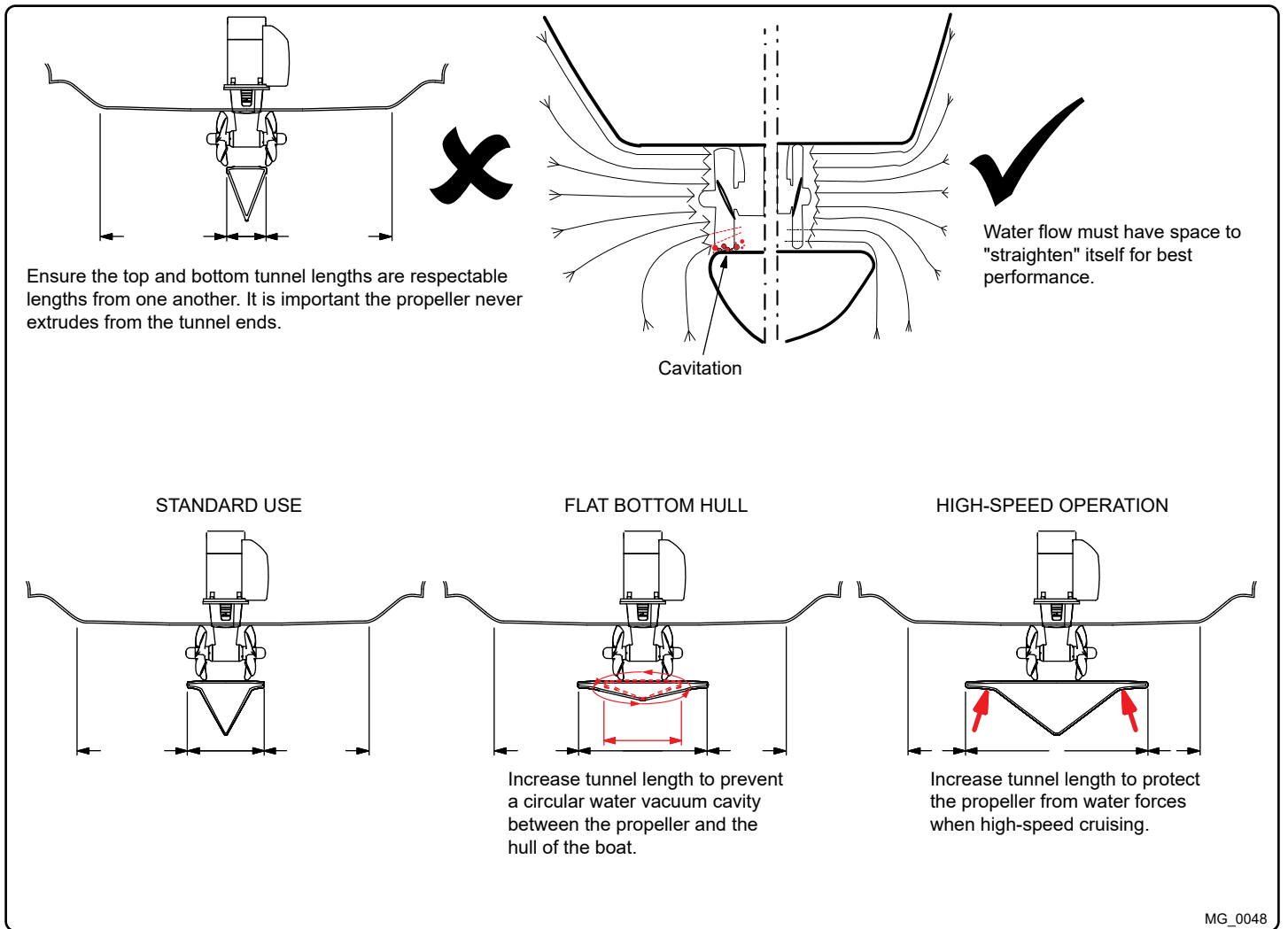

MG_0048

EN

Tunnel Length

MC_0003

Optimal tunnel length

Correct tunnel lengths depend on many factors from the hull type, operation and environmental conditions.

Tunnels should avoid being longer than 6 x the tunnel diameter as this will reduce thruster performance. **(NB: Installing tunnels at longer lengths or if added support is required for the tunnel consult a naval architect.)**

1. If the tunnel is too long, the friction inside will reduce the water speed and thereby the thrust.
2. If the tunnel is too short (typically only in the bottom section of the tunnel) cavitation problems can occur as water flow will not be able to "straighten" itself before reaching the propeller. This cavitation will reduce performance and increase noise during operation.

Thruster within the tunnel

It is important the propellers and the lower unit/ gear leg must be entirely inside the thruster tunnel. Propellers that protrude from the tunnel will not perform as intended.

Standard Use

Tunnel length must be long enough to ensure the propellers are not extruding the tunnel.

Flat Bottom Hull

Tunnel lengths must be longer than the standard measurement outlined within the manual to ensure a circular vacuum is not created between the thruster and the bottom of the boat.

High-Speed Boats

Tunnel lengths must be increased to protect the propeller from damage when crashing against the water surface during high-speed cruising. The optimal tunnel length is 3 x tunnel diameter **(NB: This can include the length of a spoiler)**

Fig. 1

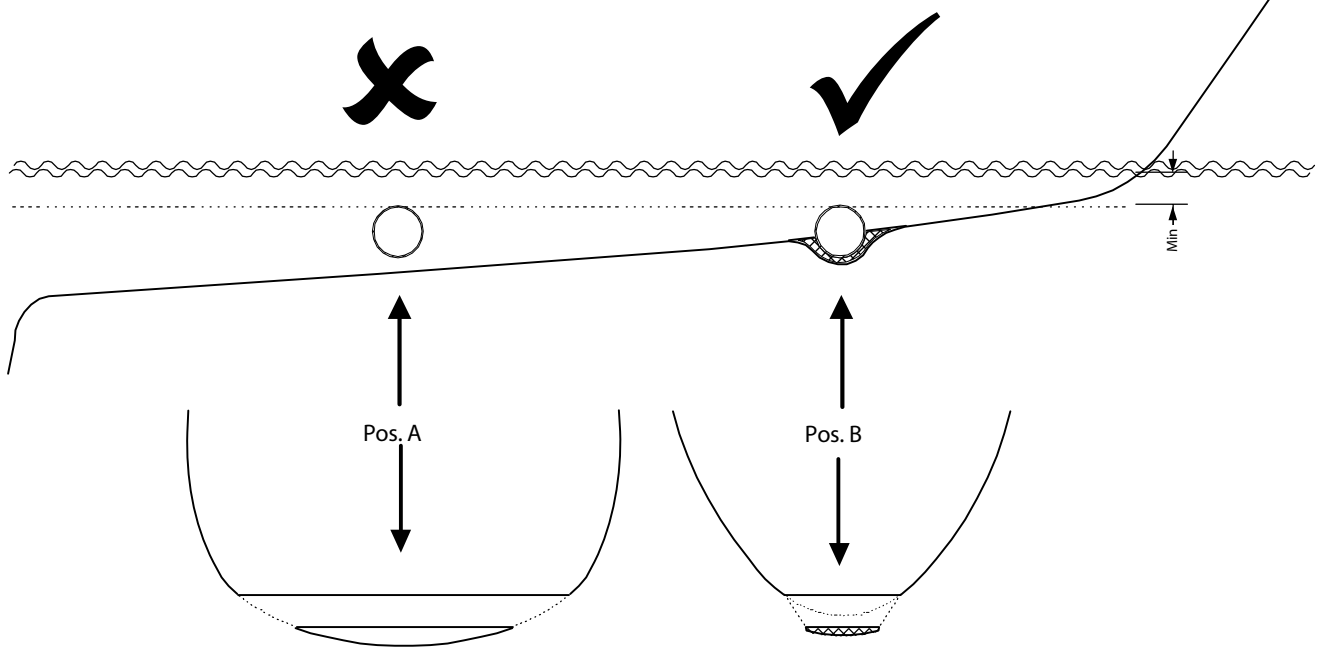

MG_0004

EN

Tunnel installation in sailboats

MC_0003

Some sailboats have a racing hull which means they may have a flat bottom and shallow draft in the bow section. This can make installing the thruster as far forward from the boats main pivot point difficult. (Fig. 1).

However, it is possible to install a tunnel thruster in most sailboats, even when the hull does not directly support the fitting of a tunnel.

Instead fit the tunnel halfway into the underneath section of the existing hull. Strengthen it with a deflector/ spoiler directing the water flow around the tunnel. This will allow installation of the thruster in the proper position on the boat, maintaining the reliability and space advantages of the tunnel thruster.

This installation is being used by some of the world's largest sailboat builders and has proven to give little to no speed loss during normal cruising. This can also be an installation method for flat bottomed barges to avoid extremely long tunnels and large oval tunnel openings in the hull.

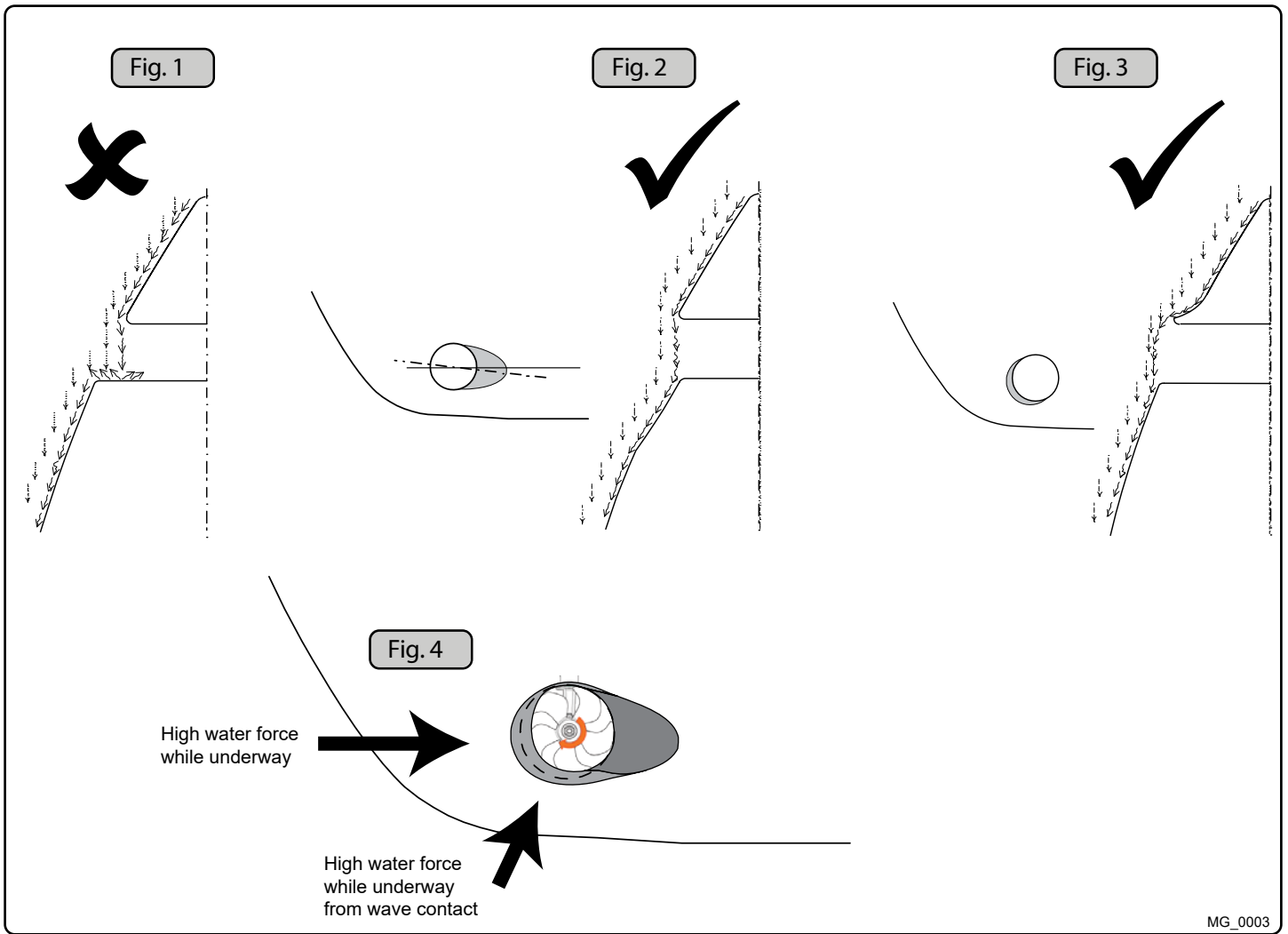

EN

Water Deflection

MC_0003

A possible problem in sailboats or fast powerboats is that a non-rounded surface can generate drag from the back face of the tunnel, as it creates a "flat" area facing the flow of water (**Fig. 1**).

The thruster propeller can spin (passively) producing noise while sailing or cruising as water is forced through the tunnel. Waterflow directed through the tunnel at high speeds, during turning or as the boat bumps waves while underway can also damage the thruster (**Fig. 4**).

This problem can be solved in two different ways, depending on what is possible or easier to perform.

1. The best solution which generally reduces the most drag is to make a recess in the hull at the back of the tunnel. As the back face is removed water can flow freely past the tunnel entry. The depth and shape of this recess will depend on the boat and the angle facing up/ down aft of the tunnel insert. Normally it is angled slightly down because of the water flow on this area (**Fig. 2**).
2. Making a deflector/ spoiler in front and underneath the tunnel can also reduce damage to the thruster and drag. The deflector/ spoiler will push the water flow out from the hull so water can pass by the back face of the tunnel. The shape and size of this deflector/ spoiler will depend on the hull shape. The easiest way of making the deflector/ spoiler is to retain a part of the lower forward area of the tunnel while installing the tube. Use this area as support to mould a soft curve/spoiler shape from the hull. (**Fig. 3**).

(NB: As a rule, you should not see the back face of the tunnel when standing directly in front of the boat looking aft.)

(NB: Remember always round the tunnel ends as much as possible to get optimum thruster performance and minimum noise.)

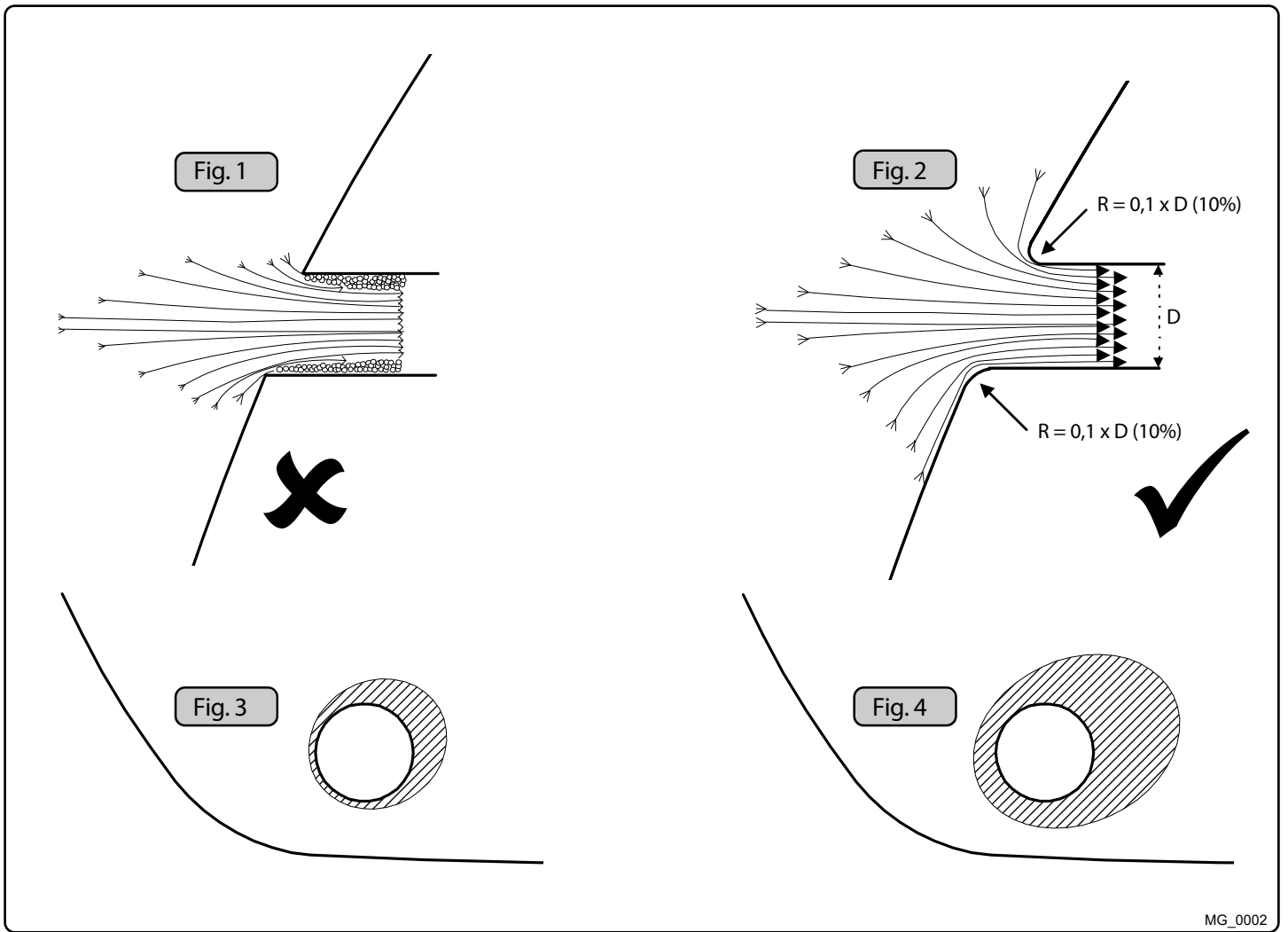

MG_0002

EN

Tunnel ends

MC_0003

Rounded tunnel ends will maximise thrust and minimise noise.

For best performance round the tunnel connection to the hull-side as much as possible. The optimum rounding has a radius of 10% of the diameter of the tunnel.

Significant advantages of a rounded tunnel over a sharp tunnel to hull connections are:

1. A rounded tunnel end will prevent the creation of turbulence/ cavitation created from a sharp tunnel end when water passes by fast. **(Fig. 1&2)**.
 - The turbulence/ cavitation will block the outer area of the tunnel and thereby reduces the effective tunnel diameter and thrust.
 - The turbulence/ cavitation hits the propeller and will lessen the propellers performance and create excess noise.
2. A rounded tunnel end makes the thruster draw water from along the hull-side, creating a vacuum that will suck the boat sideways and thereby give additional thrust **(Fig. 3&4)**.
 - With a sharp tunnel end, the thruster will be unable to take water from along the hull-side, and you will not gain the desired vacuum and additional thrust. This "free" extra thrust in optimal installations be 30 - 40% of the total thrust.

(NB: A Side-power thruster propeller does not produce cavitation at working speed. Therefore, any cavitation and cavitation noise in the tunnel will be caused during improper tunnel installation.)

(NB: It is essential to round the tunnel end as much as possible. If it is not possible to round edges an angled tunnel to hull connection can also offer similar performance as a rounded connection.)

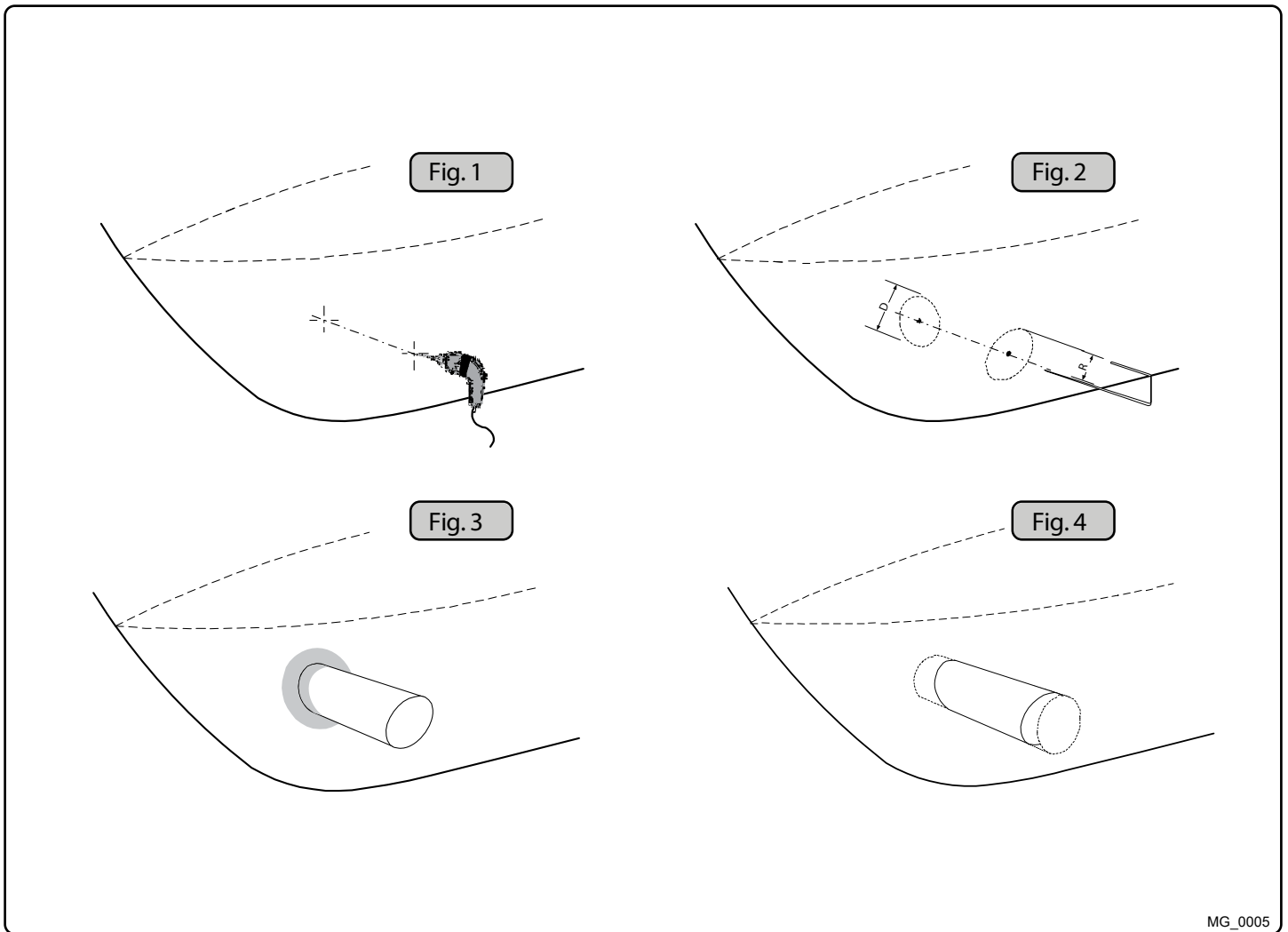

MG_0005

EN

Tunnel installation

MC_0003

IMPORTANT

We recommend that a professional does the fibreglass fitting of the tunnel. These instructions are only general instructions and do not explain in any way the details of fibreglass work. Problems caused by faulty installation of the tunnel, are the installers full responsibility.

1. Find the position in the boat considering the information earlier in this manual and the applicable measurements for the thruster model you are installing. Mark the centre of the tunnel on both sides of the hull. Drill a 6mm hole horizontally at these marks (**Fig. 1**). **(NB: it is critical that the thruster tunnel installed is perpendicular to the boats' centre line)**
2. Bend a steel bar as shown with the "tip" bent back set to the tunnel radius. Ensure the length of the bar runs through both holes. Mark the circle for the tunnel opening (outside diameter of the tunnel). Cut the hole with a jigsaw (**Fig. 2**).
3. Grind off the gel coat and polyester so that you are in the "real fibreglass" area 12cm around the hole on both inside and outside the hull to cast the tunnel to the hull (**Fig. 3**).
4. Insert the tunnel and mark its shape to fit the hull (**Fig. 4**). **(NB: if you are installing with a deflector/ spoiler, leave a part of the tunnel in the front and underside of the tunnel that will cover the back face.)**
5. Cut the tunnel ends to the desired shape and lightly sand its surface and clean with acetone or similar where you are going to apply fibreglass. **(NB: Do not cast/ fibreglass on the area were the thruster will be placed.)**
6. Cast the tunnel to the inside of the hull, use at least eight layers of 300g fibreglass and resin, preferably alternating mat and rowing types of fibreglass. If you are rounding the tunnel ends to the perfect 10% radius you may need to make further layers inside to preserve the desired hull thickness. *(See next page)*

(NB: Make sure that any gaps between the tunnel and the hull are completely filled with resin/ fibreglass. In areas where you can not access to make normal layers of resin/ fibreglass, a resin/ fibreglass mixture must be used in that area.)

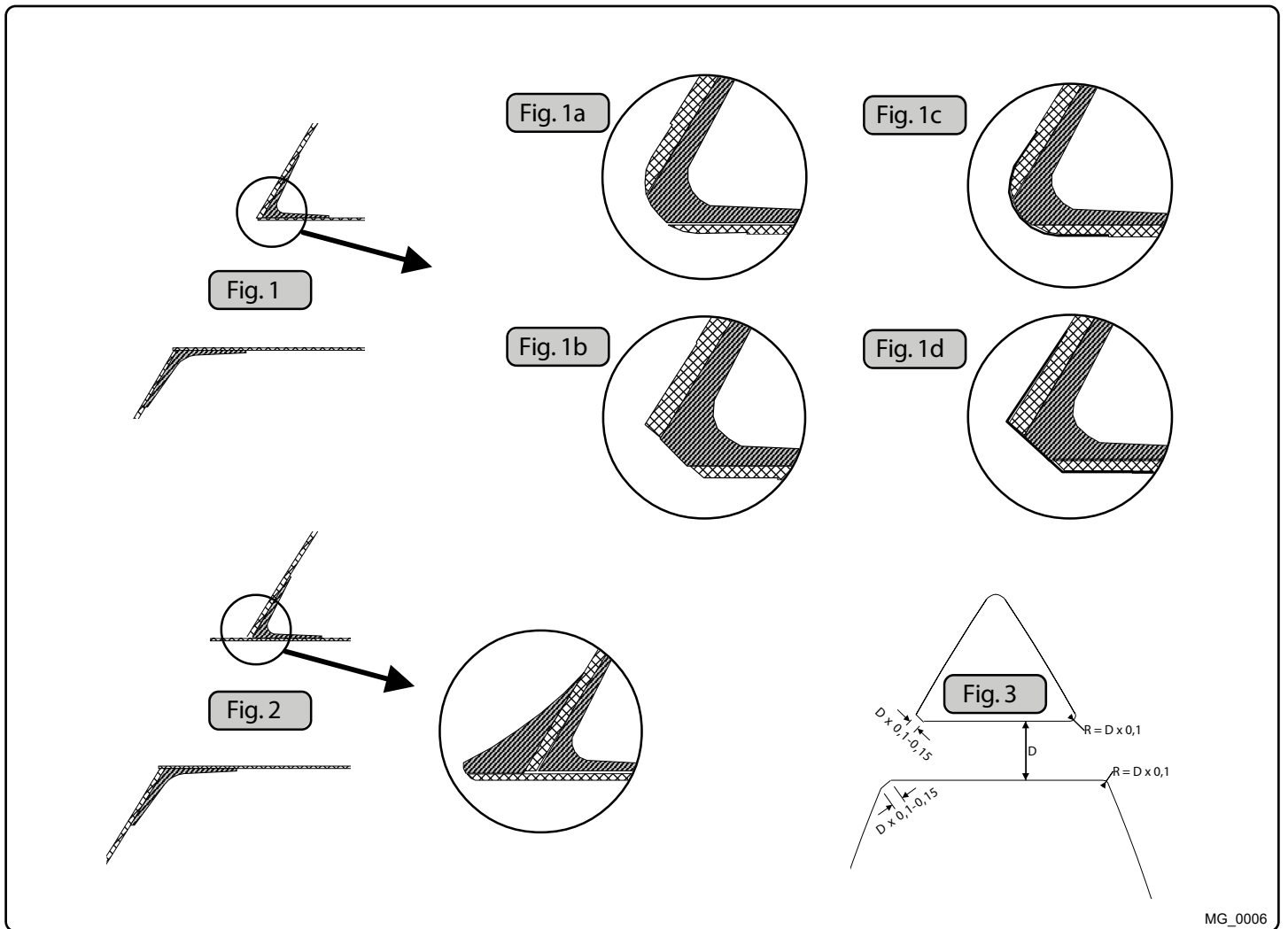

EN

Tunnel installation

MC_0003

With tunnel installed and cast (**Fig. 1**) round the edges with a radius of 10% of the tunnel diameter (**Fig. 1a**) or make a slope with a length of 10-15% of the tunnel diameter (**Fig. 1b**). If this is not possible, round the tunnel end as much as possible.

Follow the same method if making the deflector/ spoiler (**Fig. 2**).

We advise to additionally cast two layers on the outside of the tunnel/ hull in a 10cm area (**Fig. 1c & 1d**).

You must apply topcoat/ epoxy to areas outside where you have grounded/ moulded to make these areas waterproof. These areas allow water access to the hull which is typically not waterproof without these applications outside. **(NB: All original Side-Power tunnels are fully waterproof when delivered except in the areas where you have cut and bonded it to the hull.)**

If you desire to have another colour on the tunnel, you do not need to apply topcoat or the several layers of primer that is necessary on the boats' hull to make it water-resistant. Sand it very lightly and apply one coat of primer to make the anti-fouling sit.

(NB: Avoid all casting where the motor-bracket is to be placed, as this will cause misfit and possible failure to the gear house.)

Stern thruster installation has extra considerations and precautions and thruster installation procedures.

See the attached manual supplied in the stern thruster kit



Before installation, it is important that the installer reads this guide to ensure necessary acquaintance with this product.

- The electromotor must be handled with care. Do not lift it by internal connections/ main terminals or placed down on the driveshaft.
- With the boat on land, run the thruster for short bursts.
- While the thruster is in the air, ensure that the propellers have come to a complete stop before performing a directional change of the thruster, as it might cause damage to the thruster.
- It is important to follow the guidelines in this manual. Failure can result in sever damage to the thruster.

DC Ignition Protected Thrusters:

- If there is a problem with your Ignition Protected stern thruster, please contact your dealer.

NEVER

Disassemble any part of the Ignition Protected stern thruster assembly. Tampering with the Ignition Protected stern thruster assembly or any attempt to disassemble anything on this thruster assembly inside the boat can cause an explosion with severe consequences.

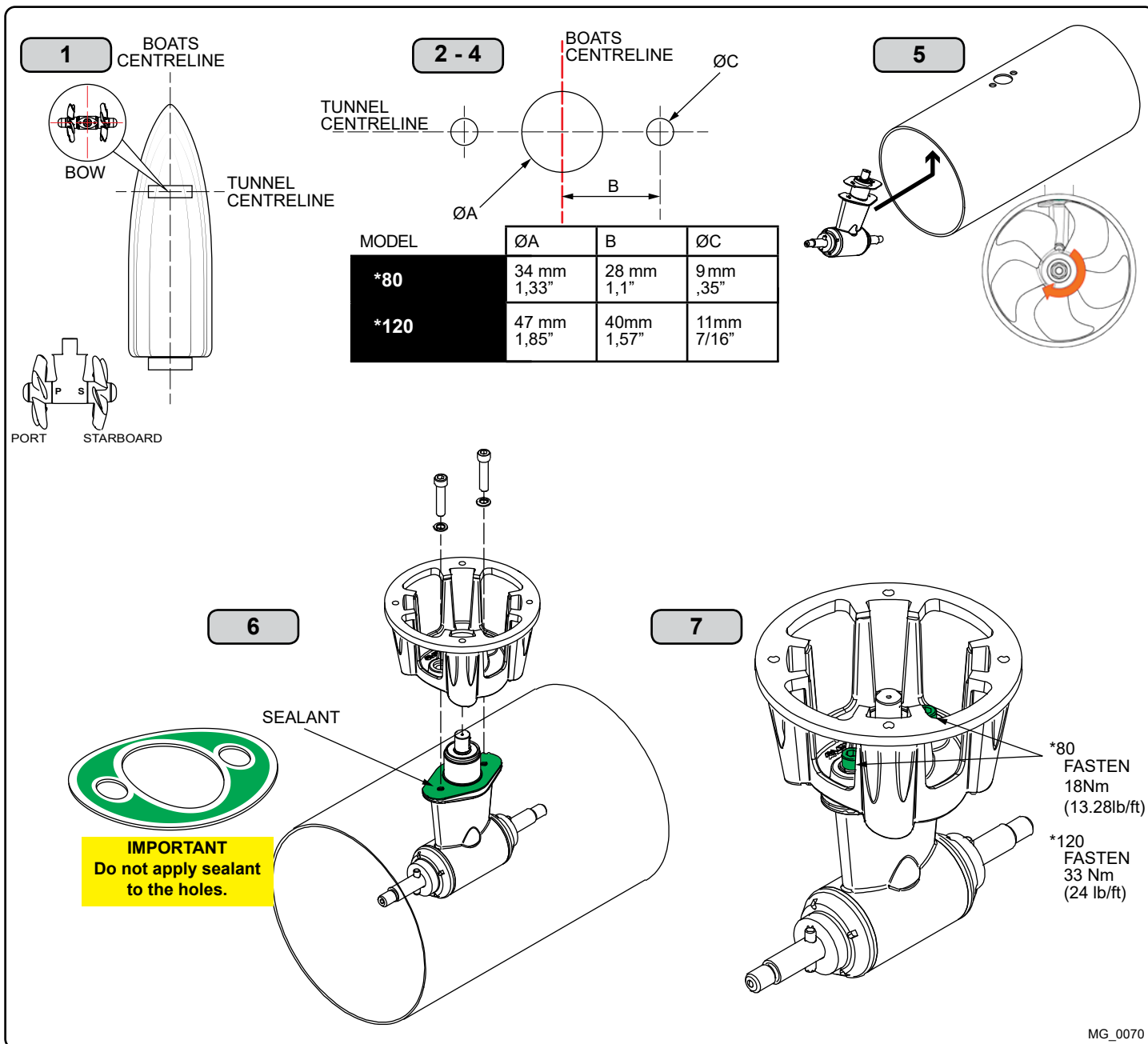

MG_0070

EN **Gear Leg & Motor Bracket Installation** **MC_0001**

! Please refer to the graphic for special considerations relating to your model !

1. Mark the tunnel centreline and the boat's centreline. **(NB: Install the gear leg and propeller(s) as shown above for the thrust direction to correspond with the control panel. If installing a twin propeller, place gear leg with the P-mark facing port and the S-mark facing starboard.)**
2. Use the gasket or template (recommended) to mark the centre of the holes and double check the measurements. One hole MUST be with the boat centreline as its centre as shown above. **(NB: All holes must be in-line with the tunnels' centreline for correct installation, as the clearance between the propeller and the tunnel is minimal.)**
3. There must be no casting where the motor bracket is to be installed, as this will cause possible failure to the gear leg. The motor bracket must rest steady on the tunnel. If the tunnel is not smooth, all bumps or uneven parts must be ground flat.
4. Drill the main-hole and then the screw-holes.
5. Place the gear leg in the tunnel (without the propeller) with the gasket inside the tunnel. Place the propeller(s) to ensure it is in the centre of the tunnel and rotates freely with the same clearance from each blade to the tunnel wall. If propeller(s) rotate off centre, try to use the other or both gaskets.
6. Remove the gear leg and propeller for final installation. Apply MS Polymer sealant or equal to both sides of the gasket, and then run the gear leg shaft through the central hole in the tunnel. With the gasket install the gear leg and motor bracket gently together. Use suited sealant to ensure that no leakages occur. **(NB: See your sealant datasheet for the correct application process.)**
7. Fasten the gear leg and the motor bracket with the bolts provided. Fasten to torque as shown above.

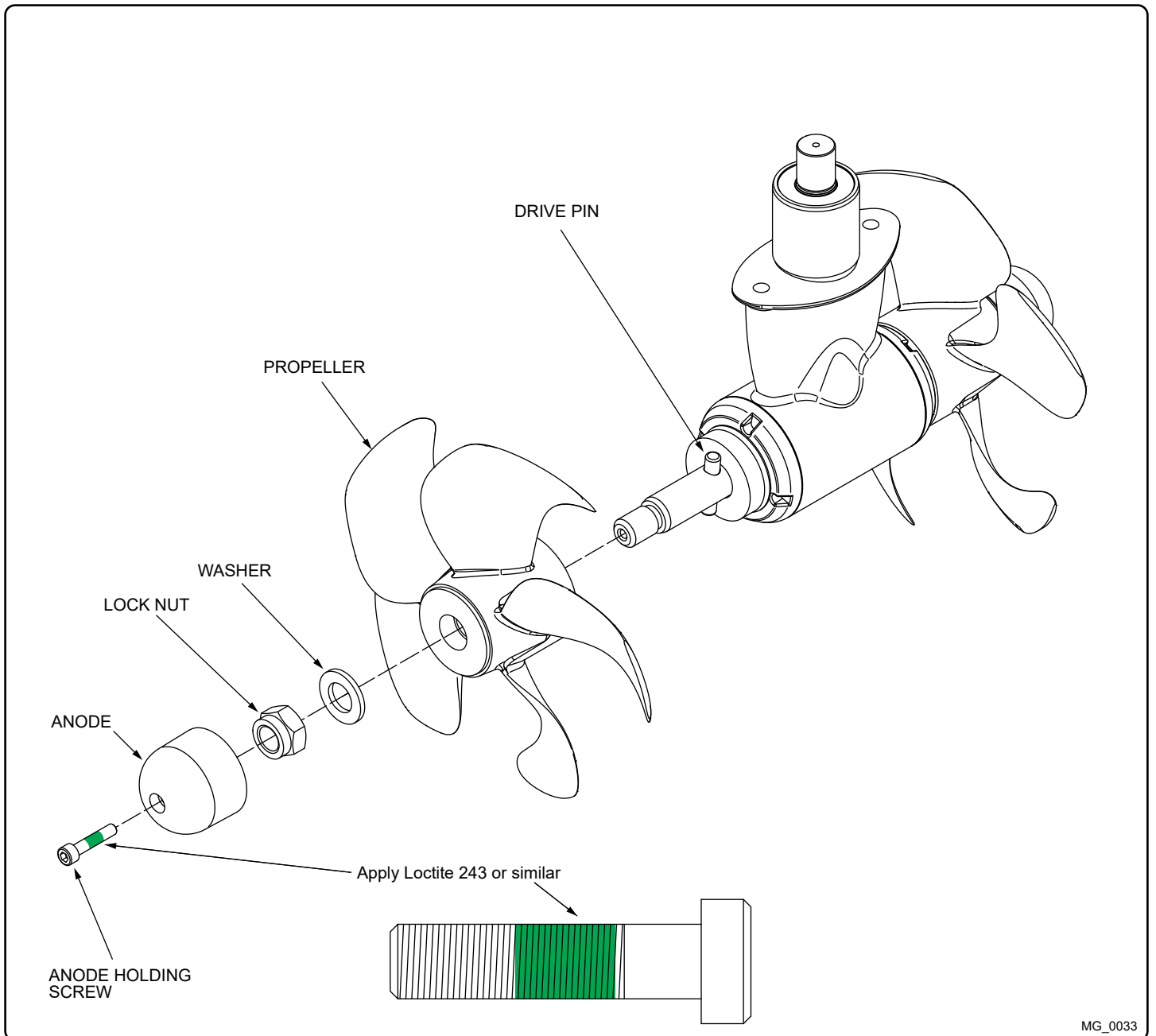

EN Propeller Installation MC_0018

! Please refer to the graphic for special considerations relating to your model !

1. Centre the drive pin and rotate the propeller shaft, so the pin is in a horizontal state.
2. Insert the propeller onto the shaft and rotate the propeller until the drive pin aligns into the slot/ groove in the propeller. **(NB: Installation requires almost no gap (approximately 1mm) between the propeller and the gear leg.)**
3. Insert the washer on the propeller shaft and fasten the propeller lock-nut. **(NB: Ensure the propeller turns freely.)**
4. Insert the anode to the end of the propeller and fasten the anode holding screw. Apply a thread glue (Loctite 243 or similar) to ensure that the anode holding screw does not un-screw itself from during the rotation of the propeller. **(NB: Apply Loctite 243 or similar to the middle of the screw)**

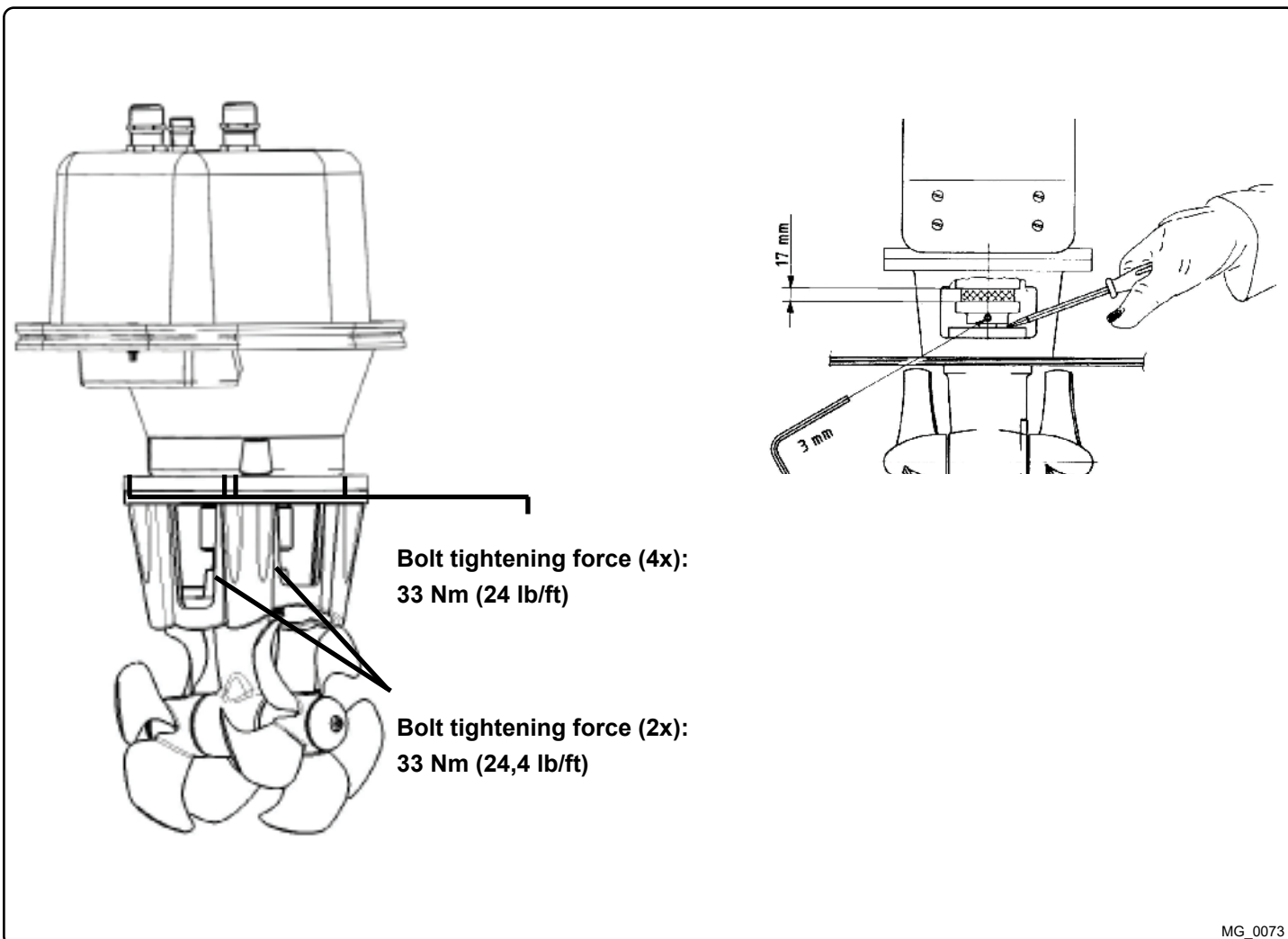

MG_0073

EN

Motor Installation

MC_0019

! Please refer to the graphic for special considerations relating to your model !

1. Install the motor onto the motor bracket ensuring both the couplings and the drive shafts have locked together. **(NB: depending on your coupling you may need to wiggle the motor into place. Ensure the connection couplings are engaging correctly. The motor can be placed in all directions on the motor bracket. However, ensure the cable terminals are accessible for electrical installation later.)**
2. Fasten the motor loosely to the motor bracket with the provided bolts. **(NB: If you are installing the motor at an angle of more than 30° off vertical, the motor will require separate/ additional support.)**
3. Fasten the bolts holding the motor to the motor bracket with the above torque.
4. Check the drive shafts engage by rotating the propeller. It is required the propeller can rotate via hand power. **(NB: Rotating the propellers can be hard because of the gear reduction and the motor.)**
5. Apply the gear leg and propeller with antifouling designed for propellers. Do not apply to the propeller drive shaft, the anodes or the end of the gear leg facing the propellers.

Only in shallow installations in workboat and fishing boats we recommend protecting the propeller by installing a grid in the tunnel opening. **(NB: Keep the grid configuration to a minimum to ensure water flow for the thruster is not significantly affected. Be aware that any grid configuration will change the effectiveness of the thruster and circular profile steel will decrease thrust significantly.)**

(NB: The motor must be covered to avoid dust from fabrication/ maintenance operation entering the motor or the solenoids. After fabrication maintenance operations have ceased the cover must be removed before operating the thruster.)

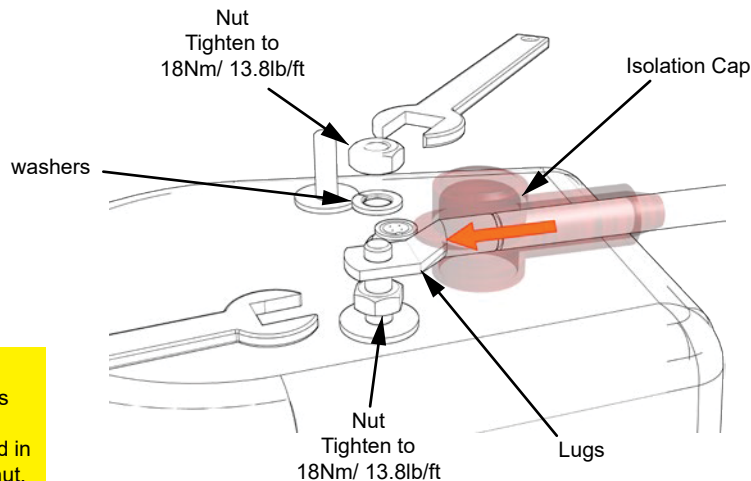
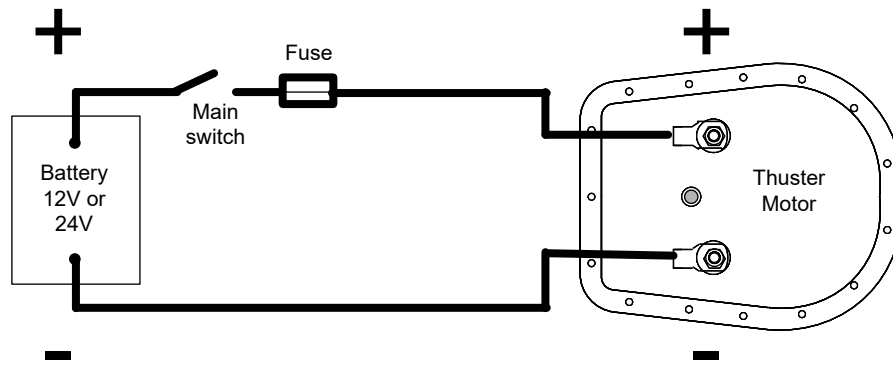

IMPORTANT
Do NOT use washers between lugs and terminals, this can cause overheating. Washers must be placed in the outer position before tightening nut.

MG_0020



Thruster Electrical Installation

MC_0143

! Please refer to the graphic for special considerations relating to your model !

1. Explanation of electrical table. *see next page*
 - All power cable lengths are the total of + and - (to and from).
 - Battery size is stated as minimum cold crank capacity, not Ah.
 - Use slow fuse rated to hold stated Amp-Draw for min. 5 minutes.
 - * Cable size and main battery size when an extra bow battery with minimum the CCA mentioned as A is installed.
2. Use appropriate sized cables and batteries with a high cranking capacity to feed the thruster. The actual voltage at the motor while running the thruster decides the motors output RPM and thrust. You can use larger cables for better results.
 - Advised minimum cables and batteries sizes. *See next page.*
3. Install the main switch in the main positive lead that can take the load without noticeable voltage drop and that can be turned off independently when not on board or in emergencies. Ensure it is easily accessible and update instructions that this should be turned off like the boat's other main switches.
 - *It is advised to install a fuse in the positive lead for protection against short-circuiting. Ensure a slow type and appropriately sized to take the amperage draw for at least 5 minutes.
 - A circuit breaker can be used instead of the fuse and main power switch If the functionality is the same.

(NB: For Ignition Protected installations remember to use ignition protected fuses and switches if fitted in areas that require this feature.)
5. Cables must have adequate electrical and mechanical isolation against contact with anything but the lead terminal on the battery and fitted with cable ends.
6. Fasten cables to the required torque. *see next page*

IMPORTANT
Check the following with the main switch set to off :
After all electrical connections have been completed check with an ohm meter that there is no electrical connection between
1. electro-motor flange and the positive terminal on the motor
2. electro-motor flange and the battery negative terminal on the motor
If unsure contact skilled personnel.



Electrical Specifications

MC_0044

*Valid for DC motors

Model Size	Voltage	Nominal current draw	Min. battery CCA	Rec. fuse	<7m total + & -		7-14m total + & -		15-21m total + & -		22-28m total + & -		28-35m total + & -		36-45m total + & -	
					Min.	Rec.	Min.	Rec.	Min.	Rec.	Min.	Rec.	Min.	Rec.	Min.	Rec.
*20/110S	12 V	150 A	DIN: 200 SAE: 380 EN: 330	ANL 150	25	35	35	50	50	70	70	70	95	95	95	2 x 95
					1	1	1	1/0	1/0	2/0	2/0	3/0	3/0	3/0	2 x 3/0	2 x 4/0
*25/110S	12 V	200 A	DIN: 200 SAE: 380 EN: 330	ANL 150	25	35	50	50	70	70	95	95	120	120	120	2 x 70
					1	1	1/0	1/0	2/0	2/0	3/0	3/0	4/0	4/0	2 x 2/0	2 x 2/0
*30/125S	12 V	245 A	DIN: 200 SAE: 380 EN: 330	ANL 150	35	50	50	70	70	95	95	120	120	120	120	2 x 70
					1	1/0	1/0	2/0	2/0	3/0	3/0	4/0	4/0	2 x 2/0	2 x 2/0	2 x 3/0
*40/125S	12 V	315 A	DIN: 300 SAE: 570 EN: 520	ANL 250	35	50	70	95	95	120	120	2 x 70	2 x 70	2 x 95	2 x 95	2 x 120
					1	1/0	2/0	3/0	3/0	4/0	4/0	2 x 3/0	2 x 3/0	2 x 4/0	2 x 4/0	
*50/140S	12 V	370 A	DIN: 350 SAE: 665 EN: 600	ANL 325	50	50	70	95	120	2 x 70	2 x 70	2 x 95	2 x 95	2 x 120	2 x 120	2 x 120
					1/0	1/0	2/0	3/0	4/0	2 x 2/0	2 x 2/0	2 x 3/0	2 x 3/0	2 x 4/0	2 x 4/0	
*60/185S	24 V	170 A	DIN: 175 SAE: 332 EN: 280	ANL 150	25	25	25	35	35	35	35	50	50	70	70	
					1	1	1	1	1	1/0	1/0	1/0	2/0	2/0	2/0	
*80/185T	12 V	530 A	DIN: 550 SAE: 1045 EN: 940	ANL 400	70	70	120	2 x 70	2 x 95	2 x 95	2 x 120	2 x 120	2 x 120	2 x 120	NA	
					2/0	2/0	4/0	2 x 2/0	2 x 3/0	2 x 3/0	2 x 4/0	2 x 4/0	2 x 4/0	340*	NA	
*100/185T	24 V	280 A	DIN: 300 SAE: 570 EN: 520	ANL 250	35	35	35	50	50	70	70	95	95	120	120	
					1	1	1	1/0	1/0	2/0	2/0	3/0	3/0	4/0	4/0	2 x 3/0
120/215T	12 V	740 A	DIN: 750 SAE: 1425 EN: 1320	ANL 500	95	95	2 x 70	2 x 95	2 x 120	280	280*	280*	320*	320*	NA	
					3/0	3/0	2 x 2/0	2 x 3/0	2 x 4/0	2 x 4/0	2 x 4/0	2 x 4/0	2 x 4/0	2 x 95	2 x 95	
*130/250T	24 V	340 A	DIN: 400 SAE: 760 EN: 680	ANL 325	50	50	50	70	70	95	95	120	120	120	2 x 95	
					1/0	1/0	1/0	2/0	2/0	3/0	3/0	4/0	4/0	4/0	2 x 3/0	2 x 4/0
*150/215T	24 V	800 A	DIN: 450 SAE: 855 EN: 760	ANL 325	70	70	70	70	70	95	95	120	120	120	2 x 70	
					2/0	2/0	2/0	2/0	2/0	3/0	3/0	4/0	4/0	4/0	2 x 2/0	2 x 2/0
170/250	24 V	550 A	DIN: 560 SAE: 1064 EN: 940	ANL 500	95	95	2 x 70	2 x 95	2 x 120	-	330	330*	375*	375*	-	
					3/0	3/0	2 x 2/0	2 x 3/0	2 x 4/0	2 x 4/0	2 x 4/0	2 x 4/0	2 x 4/0	2 x 4/0	2 x 4/0	2 x 4/0
*210/250	24 V	500 A	DIN: 400 SAE: 760 EN: 680	ANL 325	35	50	50	70	70	95	95	120	120	120	2 x 95	
					1	1/0	1/0	2/0	2/0	3/0	3/0	4/0	4/0	4/0	4/0	2 x 3/0
*250/300	24 V	610-670 A	DIN: 560 SAE: 1064 EN: 940	ANL 400-500	70	70	70	70	70	95	95	120	120	120	2 x 95	
					2/0	2/0	2/0	2/0	2/0	3/0	3/0	4/0	4/0	4/0	4/0	2 x 3/0
*300/300	24*2 48V	400-450A (48V)	DIN: 700 SAE: 1330 EN: 1170	ANL 500	70	-	95	120	120	2 x 95	2 x 95	2 x 95	2 x 95	2 x 95	2 x 120	
					2/0	2/0	3/0	4/0	4/0	4/0	4/0	4/0	4/0	4/0	2 x 4/0	
*300/300	24*2 48V	400-450A (48V)	DIN: 400 SAE: 760 EN: 680	ANL 325	50	50	50	70	70	95	95	120	120	120	140	
					1/0	1/0	1/0	2/0	2/0	2/0	3/0	3/0	4/0	4/0	4/0	

Pin 2 Pin 3 Pin 4 Pin 2 Pin 3 Pin 4

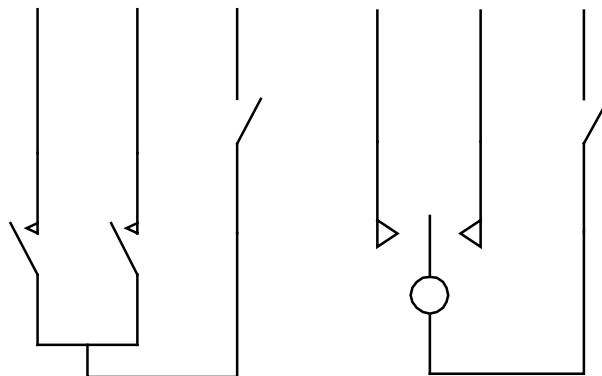
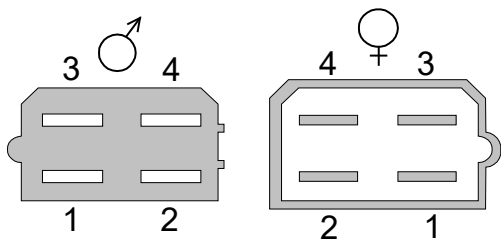

Connect round end of control adapter

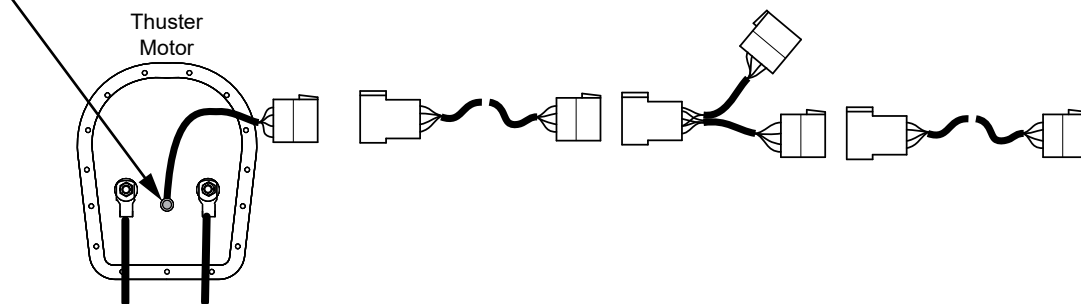

MG_0025

EN

Control Panel Cable Installation

MC_0041

! Please refer to the graphic for special considerations relating to your model !

- All standard Sidepower control panels can be used in any combination as well as any two-way switching device. If an automatic main switch is installed, a separate switch to control on/off is required.
- Many control panels can be installed using optional Y-connectors or T-connectors if installing an S-link proportional power system. **(NB: If two or more control panels are operated at the same time in opposite directions, the electronic control box will stop the thruster until it receives a single signal or thrust in one direction.)**
- When using original Sidepower equipment it is entirely "plug & go" and no additional configuration setup is required.
- All controls must have spring load for automatic return to neutral position.

(NB: If the drive direction of the thruster is running opposite to the control panel, swap the blue and grey wire on the control wire or control box solenoid.

Pin configuration of 4 pole AMP contact:

- Pin1: BLACK = Ground
- Pin2: BLUE = Engages thruster SB solenoid
- Pin3: GREY = Engages thruster Port solenoid
- Pin4: RED = Positive voltage for the control panel

NB! Very important to check the following with mainswitch in off position:

After all electrical connections have been completed check with an ohm meter that there is no electrical connection between electro-motor body and positive terminal on the motor and between the electromotor body and the negative (A1) terminal on the motor. If you feel unsure on how to perform this check, contact skilled personnel for guidance.

NB! Make sure to not use any electronic interface box (delay box) older than the 6 1232i (ex. 6 122x)

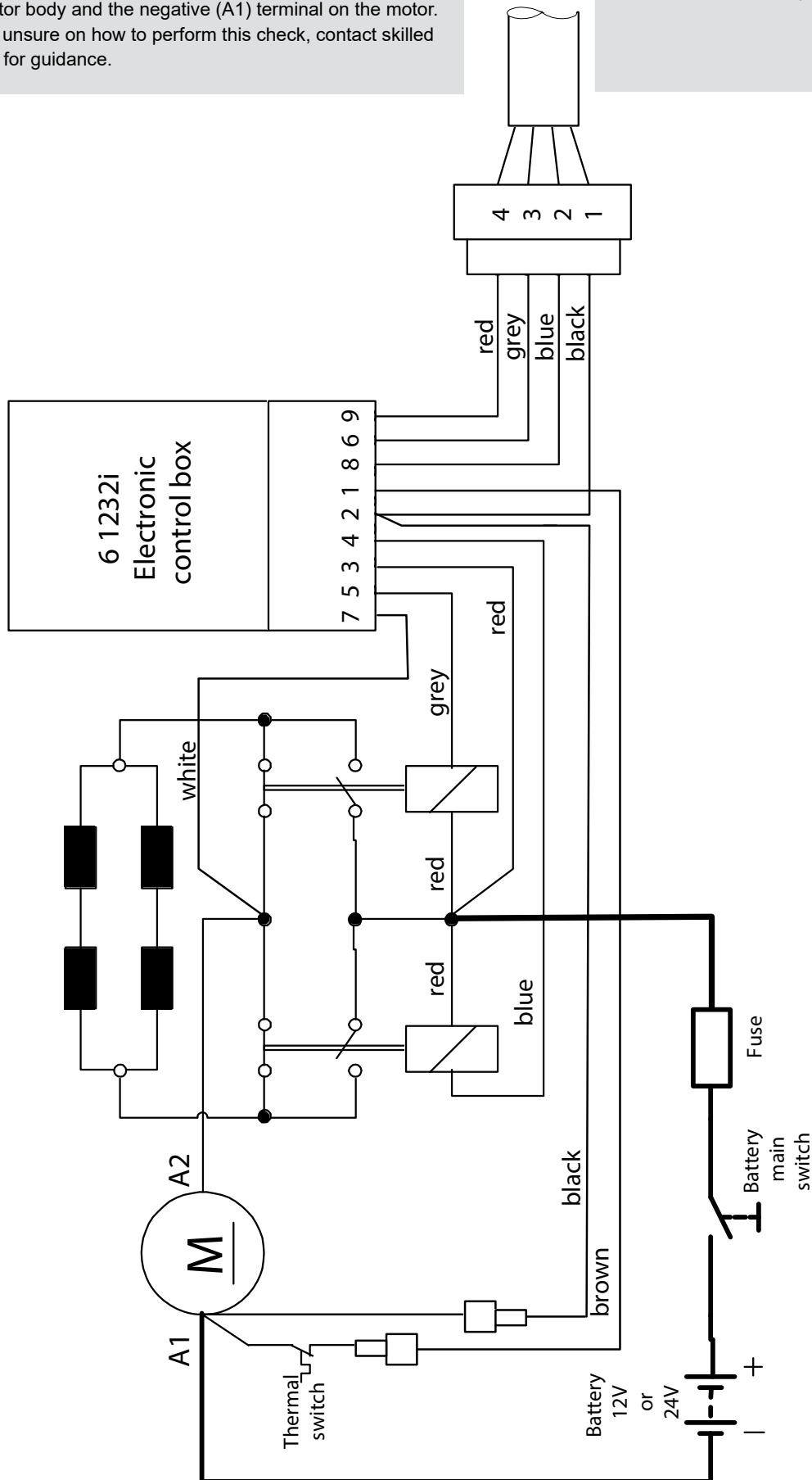

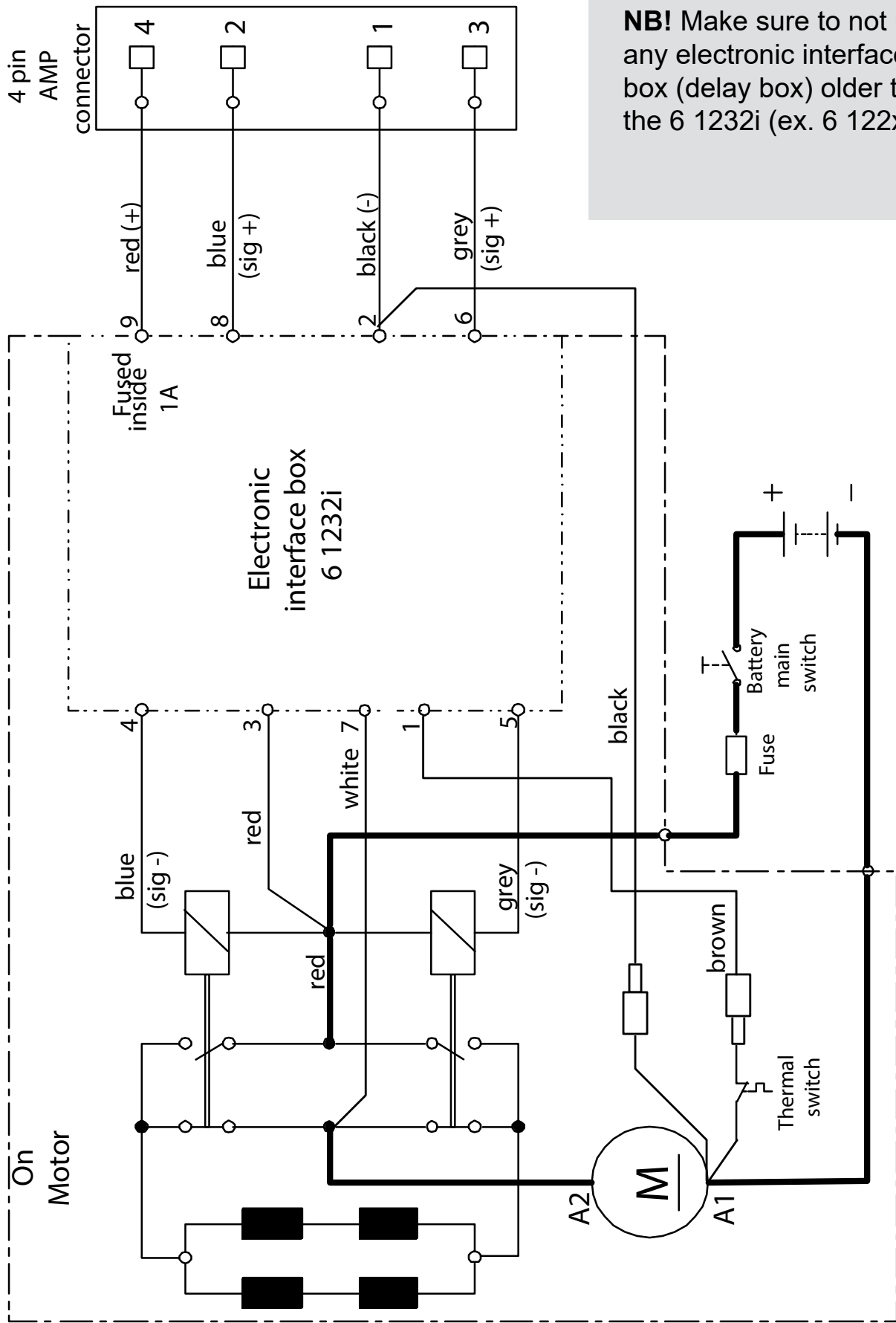

NB! Make sure to not use any electronic interface box (delay box) older than the 6 1232i (ex. 6 122x)

CONTROL PANEL TEMPLATES

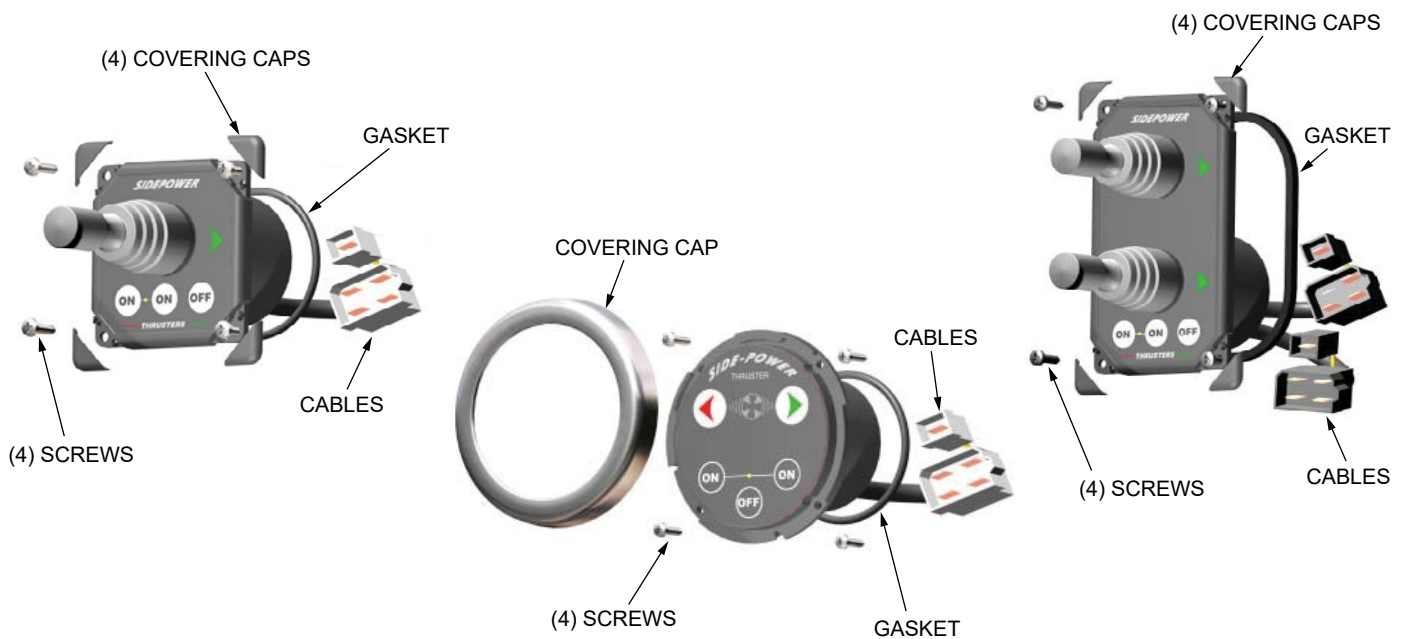
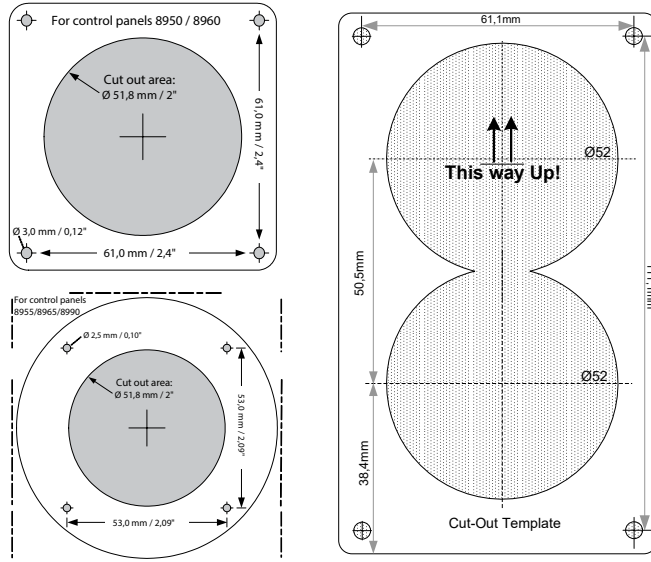

MG_0026

EN

Control Panel Installation

MC_0042

! Please refer to the graphic for special considerations relating to your model !

Find a comfortable location for the control panel where it does not obstruct or is obstructed by other controls. Install the control panel where it is easy to use. **(NB: As a guide the side thruster is often operated together with the gear/throttle control. For the optimal user-friendly solution install the control panel where access to both controls are accessible with one hand for each control.)**

1. Use the enclosed cut-out template to mark the area to remove on your control dash.
2. Cut out the area per template for the control panel. **(NB: If the front surface around your cut out is jagged or chipped, use a sealant to assist the gasket.)**
3. Place the gasket to the back face of the panel
4. Plug cables into the connectors at the rear of the control panel. **(NB: Twist the locking ring on the connector clockwise to secure connector.)**
5. Insert the control panel in place and fasten screws.
6. insert the control panels covering caps.

- Propeller is fastened correctly to the shaft.
- Propeller turns freely in tunnel.
- The anode and/or holding screw is tightened well with thread glue.
- Anti-fouling has been applied to the gearhouse and propeller but NOT on the anode or the gearhouse lid where the propeller is fastened.
- Correct drive direction as per controlpanel.
- The bolts holding the gearhouse and motorbracket together are tightened correctly.
- The bolts holding the motor to its bracket are tightened correctly.
- All electrical connections are clean, dry and tight, and the correct cable, fuse and main switch size.
- Check that there is no electrical connection between the electromotor body and positive terminal on the motor, and between the electromotor body and the negative (A1) terminal on the motor with an ohm meter.

The thruster has been installed as per the instructions in this manual and all points in checklist above have been controlled.

Signed:

Date:

Extra pre-delivery tests by installer / yard who does not use other quality control systems !

Thruster type:

Serial number:.....

Date of delivery:.....

Correct drive direction as per controlpanel:

The compartment for the thruster has been isolated from general bilge water and has no obvious or suspected risks for flooding:

.....
.....
.....

Other comments by installer:

.....
.....
.....

For the most up to date documentation, we advise you to visit our website www.side-power.com for the spare parts list.

1. The equipment manufactured by Sleipner Motor AS (The "Warrantor") is warranted to be free from defects in workmanship and materials under normal use and service.
2. This Warranty is in effect for of two years (Leisure Use) or one year (Commercial use) from the date of purchase by the user. Proof of purchase must be included, to establish that it is inside the warranty period.
3. This Warranty is transferable and covers the product for the specified time period.
4. In case any part of the equipment proves to be defective, other than those parts excluded in paragraph 5 below, the owner should do the following:
 - (a) Prepare a detailed written statement of the nature and circumstances of the defect, to the best of the Owner's knowledge, including the date of purchase, the place of purchase, the name and address of the installer, and the Purchaser's name, address and telephone number;
 - (b) The Owner should return the defective part or unit along with the statement referenced in the preceding paragraph to the warrantor, Sleipner Motor AS or an authorized Service Centre, postage/shipping prepaid and at the expense of the Purchaser;
 - (c) If upon the Warrantor's or Authorized Service Centre's examination, the defect is determined to result from defective material or workmanship, the equipment will be repaired or replaced at the Warrantor's option without charge, and returned to the Purchaser at the Warrantor's expense;
 - (d) no refund of the purchase price will be granted to the Purchaser, unless the Warrantor is unable to remedy the defect after having a reasonable number of opportunities to do so. Prior to refund of the purchase price, Purchaser must submit a statement in writing from a professional boating equipment supplier that the installation instructions of the Installation and Operation Manual have been complied with and that the defect remains;
 - (e) warranty service shall be performed only by the Warrantor, or an authorized Service Centre, and any attempt to remedy the defect by anyone else shall render this warranty void.
5. There shall be no warranty for defects or damages caused by faulty installation or hook-up, abuse or misuse of the equipment including exposure to excessive heat, salt or fresh water spray, or water immersion except for equipment specifically designed as waterproof.
6. No other express warranty is hereby given and there are no warranties which extend beyond those described in section 4 above. This Warranty is expressly in lieu of any other expressed or implied warranties, including any implied warranty of merchantability, fitness for the ordinary purposes for which such goods are used, or fitness for a particular purpose, and any other obligations on the part of the Warrantor or its employees and representatives.
7. There shall be no responsibility or liability whatsoever on the part of the Warrantor or its employees and representatives for injury to any person or persons, or damage to property, loss of income or profit, or any other consequential or resulting damage or cost which may be claimed to have been incurred through the use or sale of the equipment, including any possible failure or malfunction of the equipment, or part thereof.
8. The Warrantor assumes no liability for incidental or consequential damages of any kind including damages arising from collision with other vessels or objects.
9. This warranty gives you specific legal rights, and you may also have other rights which vary from country to country.

Area with horizontal dotted lines for writing notes.

Dotted lines for writing notes.

Worldwide sales and service



www.side-power.com



SLEIPNER MOTOR * AS P.O. Box 519 * N-1612 Fredrikstad * Norway

The information given in the document was correct at the time it was published. However, Sleipner Motor AS can not accept liability for any inaccuracies or omissions it may contain. Continuous product improvement may change the product specifications without notice. Therefore, Sleipner Motor AS can not accept liability for any possible differences between product and document.

MC_0030